

Installation and Set-up

The Model 1206 Spotlight is shipped in two Cartons:
1 - 120619XA Base Kit
2 - Head and Yoke / Pole Assembly

1. Assemble the base kit using the assembly instructions included in the carton.
2. Unpack the Yoke / Pole assembly and place the lower pole assembly into the center hub of the base and securely tighten the wing knob.
3. Place the yoke assembly with pan collar installed into the lower pole assembly. Adjust yoke to desired height and tighten gold height lever on collar securely. Adjust pan tension with a knob on lower pole.
4. Slightly loosen the yoke bolt and tilt knob located on either side of the spotlight and assure that all washers are spaced away from the spotlight body. Carefully align the bolt notches and lower light into place. Tighten tilt knob to achieve desired tilt friction.

Lamping - Installation and Set-up

(Caution) Spotlight must be disconnected from power during installation.

Installation

- The Midget Model 1206 is designed to be used with an E1000 watt lamp. Open the top door of the lamphouse by turning the two fastener 1/4 turn counter-clockwise. Insert the lamp into the lamp socket assuring that the lamp is fully seated.

240V Models use and E1000 watt 240V lamp
(this model is not U/L approved)

Setup

- The lamp alignment is adjusted at the factory. However, due to lamp tolerances, it may be necessary to realign the lamp field to achieve the desired effect. This is done by loosening the two hex nut on head screws on either side of the lamp house (A 3/32 hex key is required) and sliding the lamp bracket to obtain the desired field and then retightening the four screws. In the event the lamp "Hot Spot" is too high or too low, the socket may be adjusted by loosening the two hex nuts on the front of the lamp bracket with a 5/16" wrench, adjusting the socket as required, and re-tightening the hex nuts.

(Caution) Do not attempt to adjust hot spot while lamp is lit. Note position of hot spot. Disconnect spotlight from power line and make adjustment. Close top door and re-check alignment.

Gelling

- Five color gels are provided. Remove the color boomerang by unscrewing the two plastic knobs and lifting the entire assembly up and out. Removal is easier when the arms are slightly raised as the assembly is lifted out. Place the gels in the color frames (darkest colors away from the lamp) by switching the gel between the two rings on the arm. Insert the brass fasteners into the holes in the rings, through the gel material and fold them over securely by spreading the feet of the fastener. An alternate method of securing gels is to use wire tie wraps. Install the boomerang assembly into the spotlight, assuring that the bottom edge of the boomerang rests in the slot of the red side extrusion, and tighten the two retaining knobs.

Operation

- It is recommended that the lamp be turned on at the beginning of the performance and not turned off and turned off and on unnecessarily until the end. This will aid in extending lamp life.
- The light beam is shaped by an iris and chopping shutter. These controls are located on the top of the spotlight. A gobo slot is also provided for pattern projection. Use Lycian Model 1304 Gobo holder.
- When operating the color boomerang one or more color frames may be inserted at one time. Insertion of another color frame will release all frames. Actuating the lever to the right of the color arms will release all frames, also.
- A fader is located in the color boomerang to gradually dim the beam. This control is the arm furthest to the front of the spotlight and should be the only control used for extended periods of blackout.
- A spread lens is also located in the color boomerang, situated next to the fader. This provides a wide angle spread of light in one direction (i.e. for full stage width flood). The position of the spread angle can be adjusted by rotation of the spread lens in its holding tabs to provide flooding from various lighting angles as necessary.
- Model 1206 / D, this model incorporates an adjustable dimmer control located on the rear panel to vary the light intensity. In the full CCW position the lamp is fully off, however the fans are still operational while the on /off switch is on.

Maintenance and Service

(Caution) Disconnect light from electrical power prior to attempting any cleaning to prevent electrical shock hazard.

- **Cleaning:** Periodic cleaning of the spotlight is required for peak operation performance. The lenses may be cleaned with alcohol or lens cleaner solution. Access to the middle moving lens assembly is accomplished by removal of the color boomerang assembly. Removal of this lens should not be necessary for cleaning, however may be accomplished by unscrewing the two phillips head screws holding the baffle to the front fan and removal of the baffle, loosening the focus adjustment knob until it is removed, moving the focus lens arm inward to approximately a 45 degree angle and then sliding the lens assembly forward until clear of the supporting guide rods. The lens assembly may now be angled out through the color boomerang slot. Installation is in reverse order. Note that the non-operation side of the lens holder has a notch on which the guide rod must rest between. Failure to install the lens properly will cause the spotlight to no focus properly. Assure that the baffle is re-installed. This baffle reduces reflected light from being emitted from the unit.
- The spotlight may be cleaned with a soap and water solution and wiped dry.
- **Replacement of parts -** The Model 1206 is easily serviced and most parts are field replaceable. To assure continued U/L compatibility and safe operation only original replacement electrical parts should be used.

Schematic-Shown below in Fig. 1 is the wiring diagram for the spotlight to aid in locating electrical problems. Refer to the table below to aid in trouble-shooting.

| Problem | Probable Cause |
|--------------------------------------|---|
| 1.) Lamp will not light (switch lit) | 1.) Lamp defective; power switch defective; socket defective; loose wire; lamp improperly seated. |
| 2.) Fan (s) inoperative (lamp lit) | 2.) Verify no obstructions. Fan plug(s) loose; fan(s) defective; fan cable defective. |

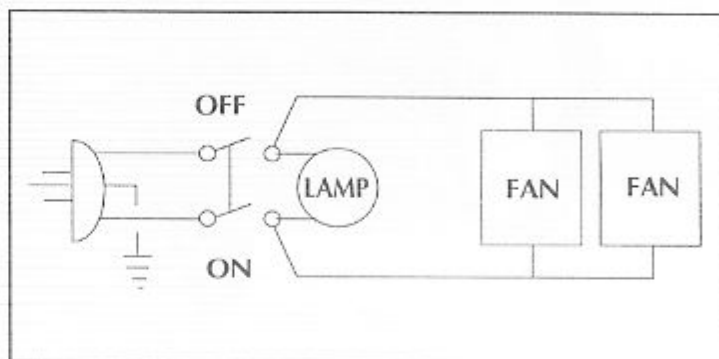

FIG. 1

Mechanical

- **Iris replacement:** Remove the color boomerang, the two ball knobs from the shutter and iris controls, the aperture cover, the fan baffle and the middle moving lens. Locate the three slotted fillister head screws on the plate directly to the rear of the middle moving lens assembly. Removal of these screws allows the entire shutter and iris assembly to be lifted up and out of the spotlight. Note that the Gobo holder bracket is also mounted on these screws between the iris and front plate. Remove the iris from the shutter mounting plate by loosening the two hex nuts using a 5/16" wrench or nut driver. Carefully lift the iris assembly from the two studs, assuring that the flat washers beneath the iris are not removed. These flat washers provide clearance for the iris pivot pins and must be in place upon replacement for proper operation of the iris. Install the new iris onto the stud and re-install the star lock washers and hex nuts. Tighten securely. Installation into the unit is in the reverse order of removal.
- **Shutter replacement:** The shutter assembly is replaced as an entire unit and is accomplished by performing the steps required for the iris replacement. Install the iris on the new shutter assembly as indicated above. Installation as indicate above.